

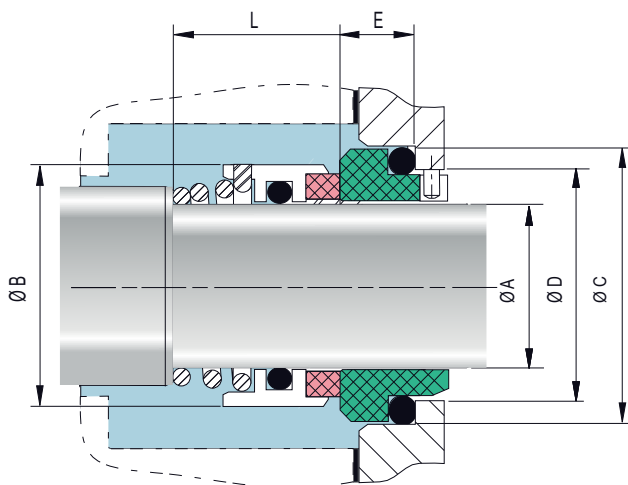

DIMENSIONES

CARACTERÍSTICAS	
Especificaciones	hasta 150 PSI a 20m/s -29° C - 232° C
Cara Estacionaria	CS, Silicio Sinterizado, CT, Cerámica
Cara Rotativa	Carbón, CS, Silicio Sinterizado, CT
Sello Secundario	NBR / EPDM / VITON
Resorte y otras Partes	AISI 316, AISI 302

Ø A	Ø B	C	D	E	L
12	21	23	19	10	16
14	23	25	21	10	16.5
16	26	27	23	10	18
18	29	33	27	11.5	19.5
20	31	35	29	11.5	22
22	33	37	31	11.5	21.5
24	35	39	33	11.5	23.5
25	36	40	34	11.5	26.5
28	40	43	37	11.5	26.5
30	43	45	39	11.5	26.5
32	46	48	42	11.5	28.5
33	47	48	42	11.5	28.5
35	49	50	44	11.5	28.5
38	53	56	49	14	33.5
40	56	58	51	14	36
43	59	61	54	14	38.5
45	61	63	56	14	39.5
48	64	66	59	14	46
50	66	70	59	15	46
53	69	73	65	15	47
55	71	75	65	15	47
58	76	78	70	15	55
60	78	80	72	15	55
65	84	85	77	15	55
70	90	92	83	18	57
75	98	97	88	18	62
80	100	105	95	18.2	61.8



NOTA: Todas las medidas son en milímetros.